

KFC-1073

SERVICE MANUAL

KENWOOD

©1990-10 PRINTED IN JAPAN
B51-6245-00(B)1430

EXTERNAL VIEW

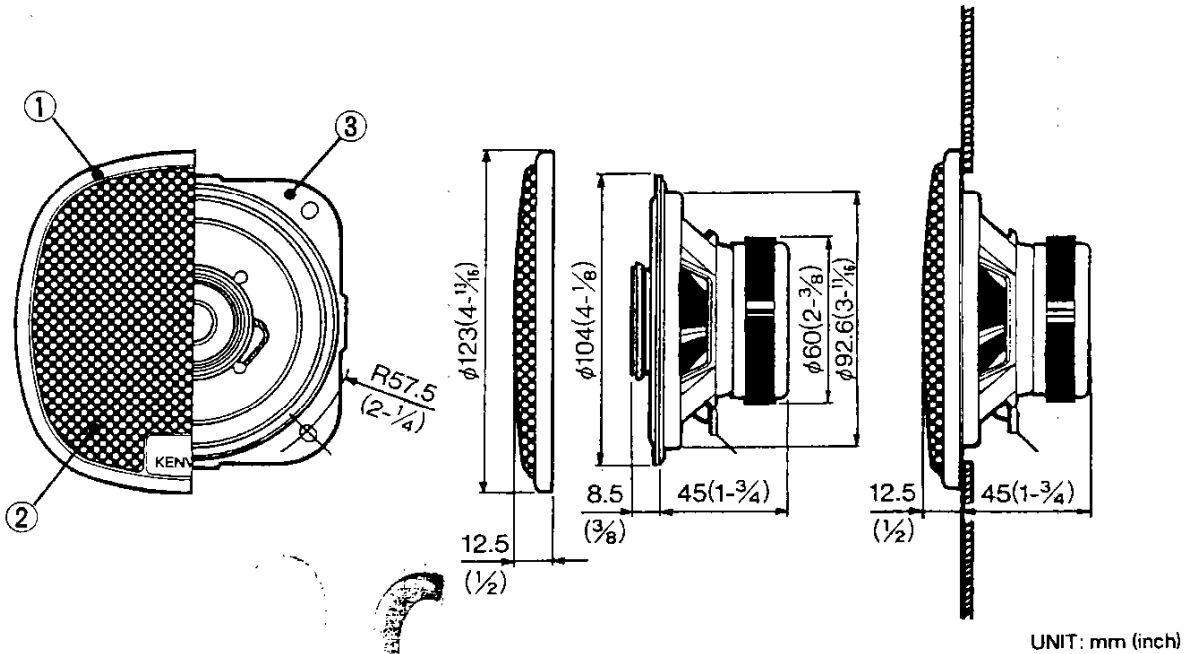

SPECIFICATIONS

Speakers

Woofers	10cm(4in) Water proof treatment Cone type 101g(3.6oz) Magnet
Tweeter	4cm(1-9/16in) cone type
Peak power	50Watts
Frequency Response	60Hz~21,000Hz
Sensitivity	90dB/W at 1m
Impedance	4 Ohms
Weight per speaker with grille	0.41Kg(14.5oz)/pc.

We follow a policy of advancements in development.
For this reason specifications may be changed without notice.

PARTS LIST

* New parts

Parts without Parts No. are not supplied.
Les articles non mentionnés dans le Parts No.
ne sont pas fournis.
Teile ohne Parts No. werden nicht geliefert.

Ref No.	New Parts	Parts No.	Description
①	*	B06-0446-08	GRILLE
		B46-0100-20	WARRANTY CARD
		E30-5059-08	CORD SET
②	*	F09-0994-08	PROTECTOR
		N99-1088-08	SCREW SET
③	*	T15-0174-08	SPEAKER